

# 納入面

図面番号

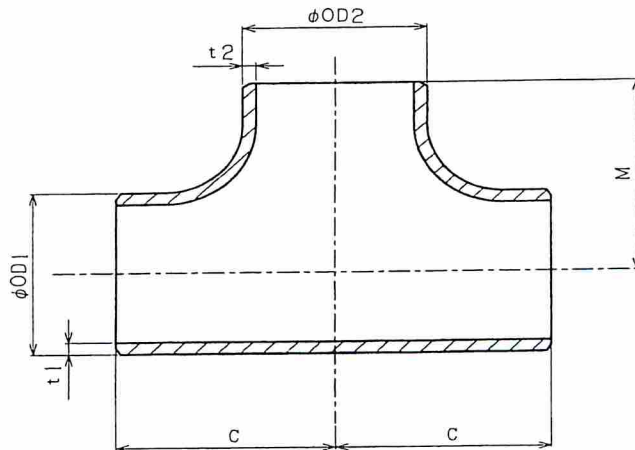

同径 T

ベベルエンドの形状、寸法

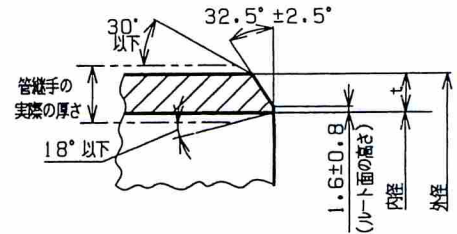

ベベルエンドの形状・寸法

径の呼び (B)	母管側			枝管側			中心から端面までの距離	
	外径 (OD1)	厚さ (t1)		外径 (OD2)	厚さ (t2)		(C)	(M)
		S40	S80		S40	S80		
1/2 × 1/2 × 1/2	21.7	2.8	3.7	21.7	2.8	3.7	25.4	25.4
3/4 × 3/4 × 3/4	27.2	2.9	3.9	27.2	2.9	3.9	28.6	28.6
1 × 1 × 1	34.0	3.4	4.5	34.0	3.4	4.5	38.1	38.1
1 1/4 × 1 1/4 × 1 1/4	42.7	3.6	4.9	42.7	3.6	4.9	47.6	47.6
1 1/2 × 1 1/2 × 1 1/2	48.6	3.7	5.1	48.6	3.7	5.1	57.2	57.2
2 × 2 × 2	60.5	3.9	5.5	60.5	3.9	5.5	63.5	63.5
2 1/2 × 2 1/2 × 2 1/2	76.3	5.2	7.0	76.3	5.2	7.0	76.2	76.2
3 × 3 × 3	89.1	5.5	7.6	89.1	5.5	7.6	85.7	85.7
3 1/2 × 3 1/2 × 3 1/2	101.6	5.7	8.1	101.6	5.7	8.1	95.3	95.3
4 × 4 × 4	114.3	6.0	8.6	114.3	6.0	8.6	104.8	104.8
5 × 5 × 5	139.8	6.6	9.5	139.8	6.6	9.5	123.8	123.8
6 × 6 × 6	165.2	7.1	11.0	165.2	7.1	11.0	142.9	142.9
8 × 8 × 8	216.3	8.2	12.7	216.3	8.2	12.7	177.8	177.8
10 × 10 × 10	267.4	9.3	15.1	267.4	9.3	15.1	215.9	215.9
12 × 12 × 12	318.5	10.3	17.4	318.5	10.3	17.4	254.0	254.0
14 × 14 × 14	355.6	11.1	19.0	355.6	11.1	19.0	279.4	279.4
16 × 16 × 16	406.4	12.7	21.4	406.4	12.7	21.4	304.8	304.8
18 × 18 × 18	457.2	14.3	23.8	457.2	14.3	23.8	342.9	342.9
20 × 20 × 20	508.0	15.1	26.2	508.0	15.1	26.2	381.0	381.0

指定なき寸法許容差は JIS B 2312 に準ずる

名称	鋼製突合せ溶接式管継手	材質	PT370	数量	—	備考	
品名	同径 T (1/2B ~ 20B)	納入先	殿				
古 林 工 業 株 式 会 社				担当	確認	承認	
				C.4 H-2.5			